

The Dual Upright Storage Locker

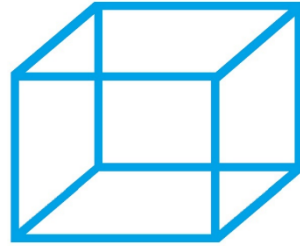

Model Number, JDUL 4000

Product Summary

The New Zealand made Jaloc Dual Upright – folded sheet metal locker is architecturally suited for an apartment garage or basement car park area.

The custom designed Dual Upright sheet metal storage locker is a secure lockable cabinet with two sliding doors designed to give maximum space storage capacity.

Removable metal shelves are supplied. They fit to 6 different positions of welded shelf supports. A total of 3.3m³ of storage space is achieved.

The locker is made from folded electro galvanised panels and posts bolted together with corner gussets. Panels are secured using mono steel rivets.

The base and shelving panels Jaloc are reinforced folded sheet metal held together using mono steel rivets for greater strength and reliability.

Door hardware is a robust surface mounted pull handle and hooked-latch lock with a key cylinder. Custom lock options are available, such as multipoint and padlock tabs.

Doors slide in folded sheet metal channels on hardened nylon wheels secured with stainless axles.

The locker uses 8 galvanised screw in M10 adjustable feet located around the locker base. The outer feet include bolt down provisions for seismic restraint.

A perforated top panel is available if the locker is situated under a buildings sprinkler system.

Visit our web site @ www.jaloc.co.nz

**THE SMART, SPACE-SAVING WAY TO KEEP BULKY ITEMS CLEAN, SECURE AND CLOSE-AT-HAND
MADE HERE IN NEW ZEALAND**

The locker can be manufactured for outside use by adaption of flashings and sealed seams to prevent water ingress. Construction from galvanised sheet steel with stainless steel rivets is sufficient for most inland environments.

Design and materials.

Locker dimensions = 2270mm long, 840mm deep, 1800mm high + Mounting feet,
Panels a constructed using .8 and .9 Electrogalv sheets JIS G3313 .06 OZ SECC phos and dry.

Lockers are designed and manufactured in New Zealand to NZ standards using CAD and CNC technology and the latest sheet metal machinery.

Surface finish is powder coating for appearance and durability. Dulux Duralloy colours by approved applicator are standard.

The Jaloc proprietary design cabinets have been developed over the years to satisfy most shared space storage needs.



Visit our web site @ www.jaloc.co.nz

**THE SMART, SPACE-SAVING WAY TO KEEP BULKY ITMES CLEAN, SECURE AND CLOSE-AT-HAND
MADE HERE IN NEW ZEALAND**

JDUL 4000-Dual Upright Storage Locker

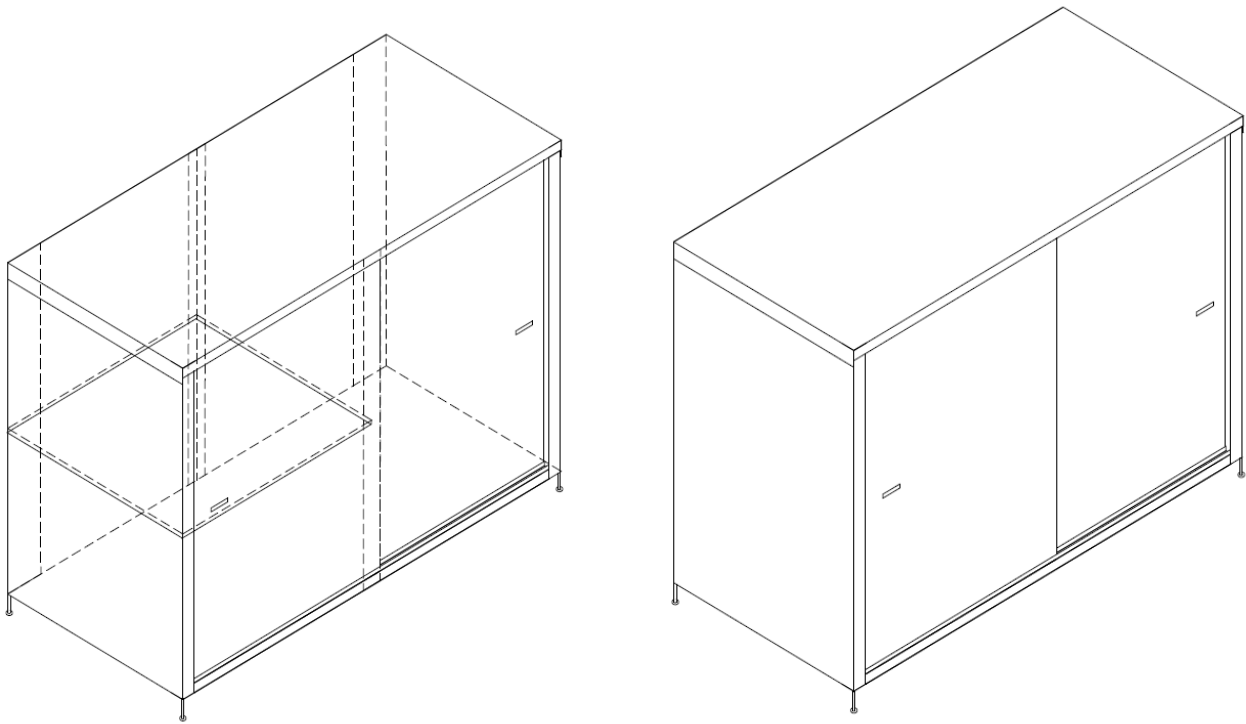

Functional Specs

- 2200mm Wide x 840mm Deep x 1800mm High
- Internal volume is Approx. $3.3 m^3$
- Door openings 2 x 1000 x 1630mm high
- Shelf Size Approx. $1 m^2$

Visit our web site @ www.jaloc.co.nz

THE SMART, SPACE-SAVING WAY TO KEEP BULKY ITEMS CLEAN, SECURE AND CLOSE-AT-HAND
MADE HERE IN NEW ZEALAND